



MANUAL

OMEGA S

IMPORTANTE

É DE EXTREMA IMPORTÂNCIA LER, COMPREENDER E SEGUIR TODAS AS INSTRUÇÕES CONTIDAS NESTE MANUAL. O MANUSEIO INCORRETO PODE DANIFICAR O EQUIPAMENTO E OCASIONAR A ANULAÇÃO DA GARANTIA.



PEÇAS INCLUSAS



Encosto
(A)



Assento
(B)



Apoio de braço
(C)

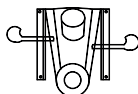

Comando de ajustes
(D)



Pistão
(E)



Capa do pistão
(F)



Base
(G)



Rodas
(H)



Capa lateral direita
(I)



Capa lateral esquerda
(J)

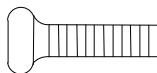

16x Parafusos MB*20mm
(K)



2x Parafusos M5*8mm
(L)



2x Tampas para parafusos
(M)



Chave Allen
(N)

MONTAGEM

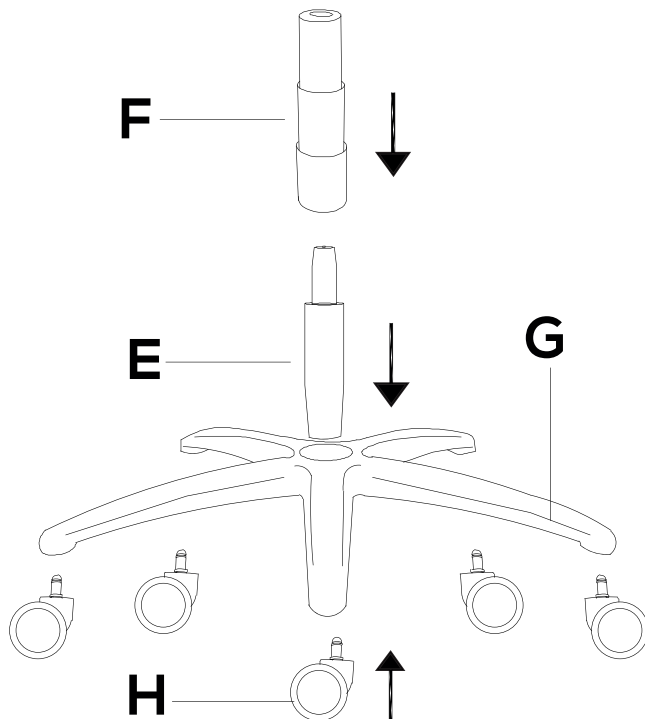

Passo 1

Insira as rodinhas (H) no encaixe da base estrelada (G). Pode ser necessário aplicar um pouco de força para encaixe das peças.

O pistão (E) deve ser inserido no centro da base estrelada na posição demonstrada na imagem, recomendamos em empurrá-lo até que fique preso na base. Por último, coloque a capa do pistão (F) sob o pistão

Perfeito, agora a base da cadeira está montada. Vamos seguir para a montagem do restante da cadeira. Caso você não tenha um local adequado para a montagem, recomendamos que utilize a caixa do produto na vertical para auxiliá-lo na montagem.

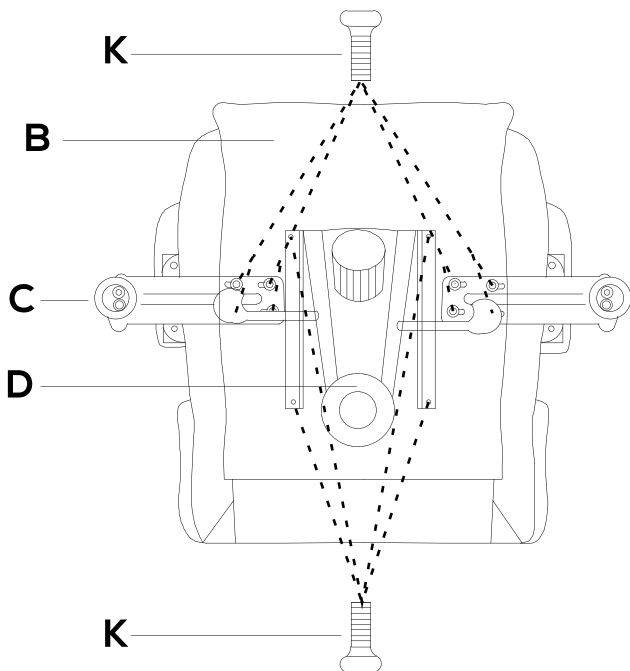

Passo 2

Com o assento (B) virado, conforme a imagem, comece instalando o comando de ajustes (D), posicione-o de acordo com as furações no assento.

Atenção: para a direção em que o comando de ajustes está sendo instalado; o produto possui um informativo dizendo o a direção correta para instalação.

Então basta inserir os parafusos (K) nas furações do comando de ajustes sob o assento e parafusá-los em X, para a pressão deseje distribuída igualmente em cada ponta.

Após a instalação do comando de ajustes, siga para a instalação dos apoios de braço (C).

Os apoios de braço possuem escrito em sua estrutura a qual lado pertencem.

Após conferir qual o apoio de braço correto, posicione-o sob a furação do assento e fixe-os utilizando os parafusos (K), lembre-se de também parafusar em X.

Perfeito, o assento e sua estrutura já estão completos. Para facilitar os próximos passos recomendamos que o assento seja conectado à base montada no passo 1.

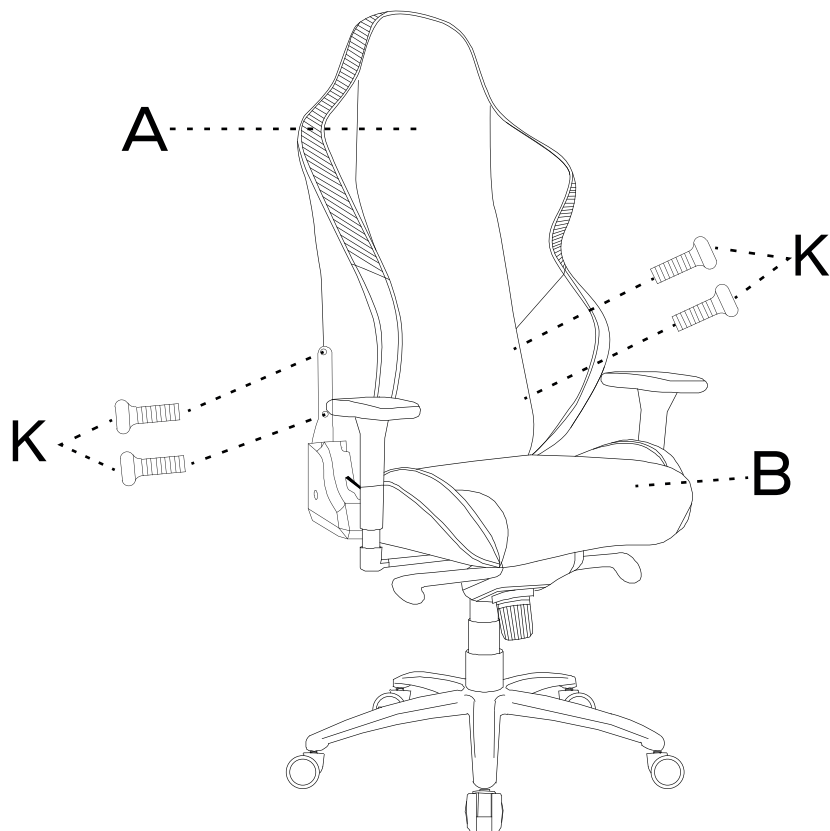

Passo 3

Agora basta posicionar o encosto (A) entre os conectores sob o assento e novamente utilizar os parafusos (K).

Recomendamos que aperte cada um dos 4 parafusos igualmente, desta forma facilitará a montagem e evitará que o encosto fique direcionado para algum dos lados.

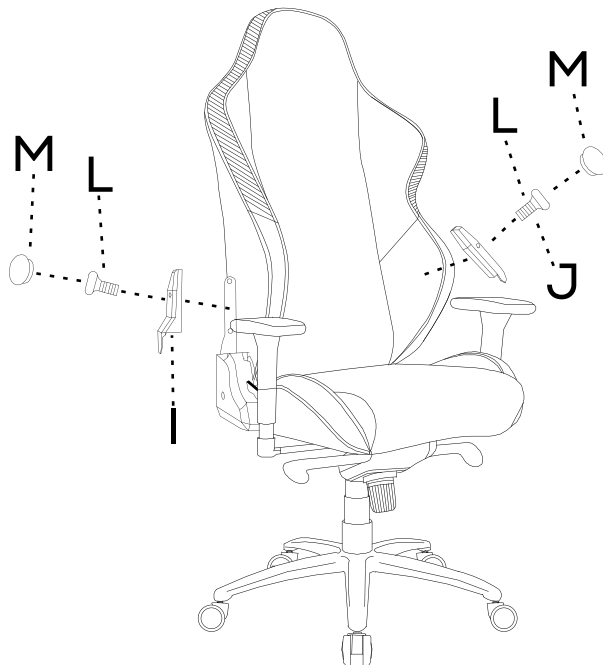

Passo 4

Agora basta instalar os acabamentos. Utilize as capas laterais (I e J) e utilize os parafusos (L) para parafusar as capas entre o assento e o encosto. Após parafusar, basta cobrir a entrada do parafuso com a tampa (M).

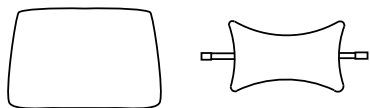

Caso prefira, pode utilizar as almofadas de apoio de cabeça e lombar para uma experiência mais confortável. No entanto, se preferir não utilizá-las, a cadeira ainda oferecerá suporte adequado.

FUNÇÕES DA CADEIRA

Mecanismo Frog:

O mecanismo Frog é composto por 2 alavancas e 1 controle de sensibilidade para o modo de balanço. A alavanca da direita ajusta a altura do pistão da cadeira, enquanto a alavanca esquerda ativa ou desativa o modo de balanço. O componente central no controle de ajustes regula a sensibilidade do modo de balanço, permitindo personalizar a experiência de inclinação da cadeira conforme preferência do usuário.

Alavanca do encosto:

Do lado direito da cadeira, você encontrará uma alavanca que permite ajustar o ângulo do encosto conforme sua preferência, proporcionando maior conforto durante o uso.

CARACTERÍSTICAS DA CADEIRA

Encosto: Reclinável

Rodinhas: Pu, 60MM

Espuma: Moldada

Descanço de braço: 4D

Base: Metal 350MM

Revestimento: Tecido + PU

Mecanismo: Frog

Ângulo de inclinação: 90-180°

Reclinação travada: Sim

Ajuste de altura: 6cm

Material do quadro: Metal

Classe do pistão: Classe 4

Densidade do encosto: 45

Densidade do assento: 45

**AGRADECEMOS POR ESCOLHER O PICHAU GROUP
COMO PARTE DA SUA JORNADA.**



**EXPLORE NOSSOS SITES E ENCONTRE O
PRODUTO IDEAL PARA ELEVAR SUA EXPERIÊNCIA.**



MANUAL | ESPANÖL

OMEGA S

IMPORTANTE

**ES DE SUMA IMPORTANCIA LEER, COMPRENDER Y
SEGUIR TODAS LAS INSTRUCCIONES CONTENIDAS EN ESTE MANUAL.
EL MANEJO INCORRECTO PUEDE DAÑAR EL EQUIPO Y CAUSAR
LA ANULACIÓN DE LA GARANTÍA.**

PIEZAS INCLUIDAS



Respaldo
(A)



Asiento
(B)



Apoyabrazos
(C)

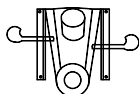

Mecanismo de ajuste
(D)



Pistón
(E)



Funda protectora del pistón
(F)



Base
(G)



Ruedas
(H)



Tapa lateral derecha
(I)



Tapa lateral izquierda
(J)

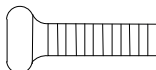

16x Tornillos M8*20mm
(K)



2x PTornillos M5*8mm
(L)



2x Tapas para tornillos
(M)



Llave Allen
(N)

INSTRUCCIONES DE MONTAJE

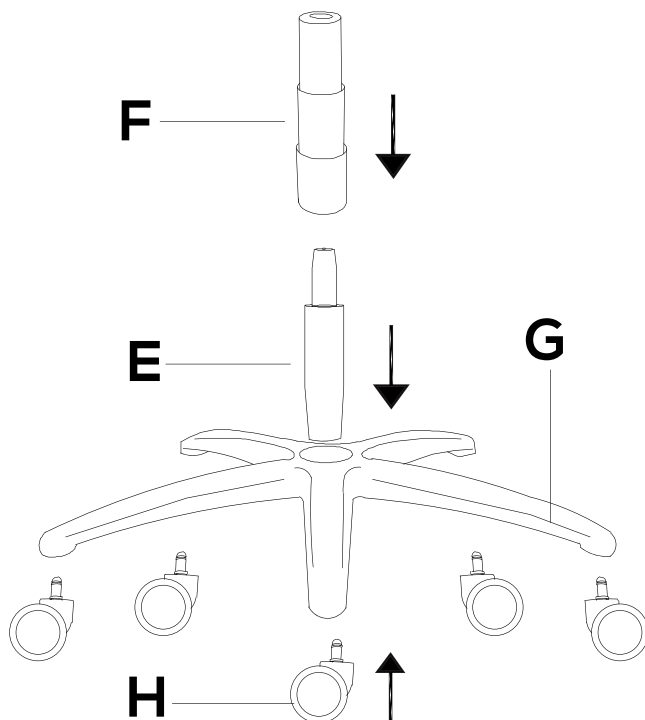

Paso 1:

Inserte las ruedas (H) en los orificios de la base de estrella (G). Puede ser necesario aplicar un poco de fuerza.

Inserte el pistón (E) en el centro de la base y presiónelo hasta que quede firme. Por último, coloque la funda protectora (F) sobre el pistón.

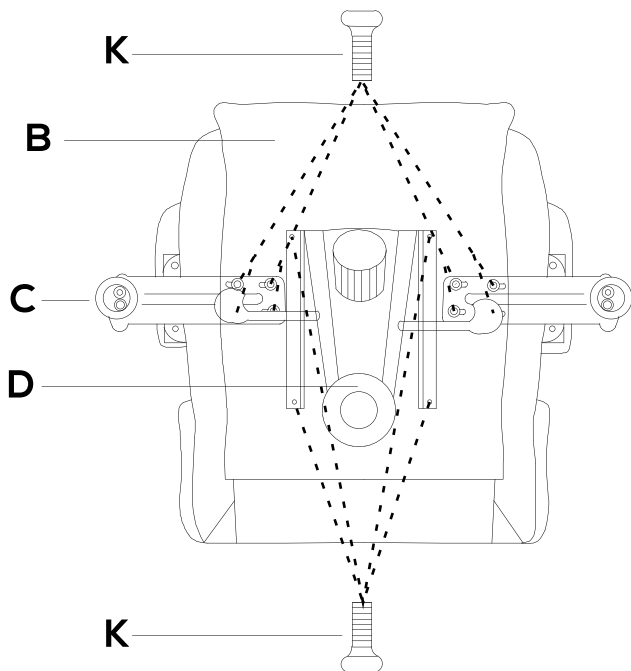

Paso 2:

Con el asiento (B) hacia abajo, instale el mecanismo de ajuste (D) alineándolo con los agujeros.

Atención: *verifique la dirección correcta indicada en el componente.*

Fije con los tornillos (K) apretando en cruz, para que la presión se distribuya igualmente. Luego, instale los apoyabrazos (C) (verifique el lado indicado en la pieza) utilizando los tornillos (K).

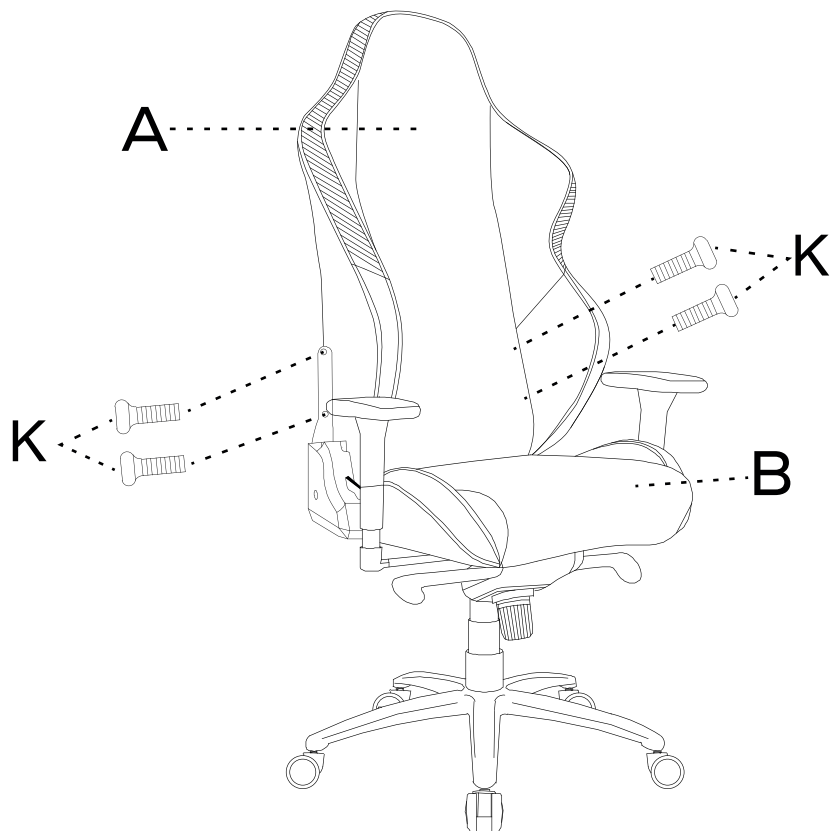

Paso 3:

Posicione el respaldo (A) entre los conectores del asiento y fíjelo con los tornillos (K). Recomendamos apretar los 4 tornillos por igual para evitar inclinaciones.

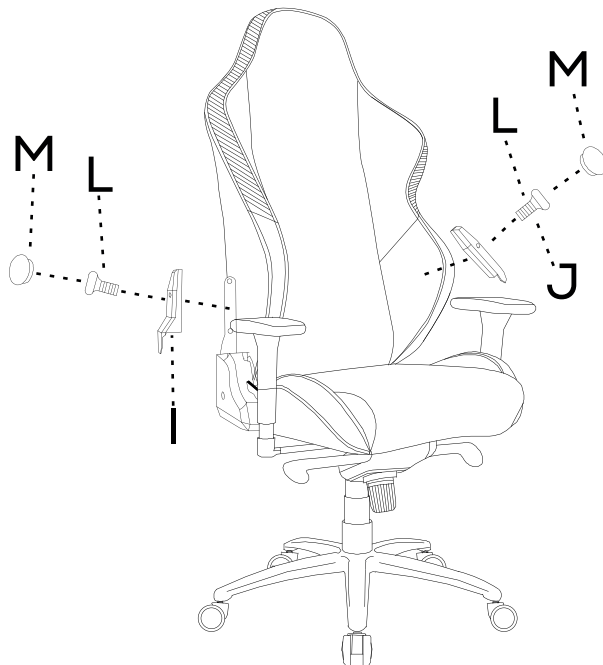

Paso 4:

Instale las tapas laterales (I y J) con los tornillos (L) y cubra el acceso con las tapas (M).

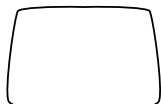

Si lo desea, coloque las almohadillas cervical y lumbar para un soporte aún mejor.

FUNCIONES

Mecanismo Frog:

El mecanismo Frog está compuesto por 2 palancas y 1 control de sensibilidad para el modo de balanceo. La palanca derecha ajusta la altura del pistón de la silla, mientras que la palanca izquierda activa o desactiva el modo de balanceo. El componente central en el control de ajustes regula la sensibilidad del modo de balanceo, permitiendo personalizar la experiencia de inclinación de la silla según la preferencia del usuario.

Palanca del respaldo:

En el lado derecho de la silla, encontrarás una palanca que permite ajustar el ángulo del respaldo según tu preferencia, proporcionando mayor comodidad durante el uso.

CARACTERÍSTICAS DE LA SILLA

Respaldo: Reclinable

Ruedas: PU, 60 mm

Espuma: Moldeada

Reposabrazos: 3D

Base: Metal 350 mm

Revestimiento: Gamuza + PU

Mecanismo: Frog

Ángulo de inclinación: 90–180°

Reclinación bloqueable: Sí

Ajuste de altura: 6 cm

Material del armazón: Metal

Clase del pistón: Clase 4

Densidad del respaldo: 45

Densidad del asiento: 45

**GRACIAS POR ELEGIR A PICHAU GROUP
COMO PARTE DE SU TRAYECTORIA.**



**EXPLORE NUESTROS SITIOS WEB Y ENCUENTRE EL
PRODUCTO IDEAL PARA ELEVAR SU EXPERIENCIA.**

IMPORTANT

IT IS EXTREMELY IMPORTANT TO READ, UNDERSTAND, AND FOLLOW ALL INSTRUCTIONS IN THIS MANUAL. INCORRECT HANDLING MAY DAMAGE THE EQUIPMENT AND VOID THE WARRANTY.



MANUAL | ENGLISH

OMEGA S

INCLUDED PARTS



Backrest
(A)



Seat
(B)

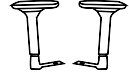

Armrests
(C)

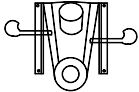

Adjustment Mechanism
(D)

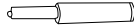

Gas Lift (Piston)
(E)

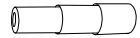

Gas Lift Cover
(F)

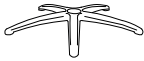

Base
(G)



Castors (Wheels)
(H)



Right Side Covers
(I)



Left Side Covers
(J)

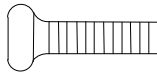

16x M8*20mm Screws
(K)



2x M5*8mm Screws
(L)



2x Screw Caps
(M)



Allen Key Wrench
(N)

ASSEMBLY INSTRUCTIONS

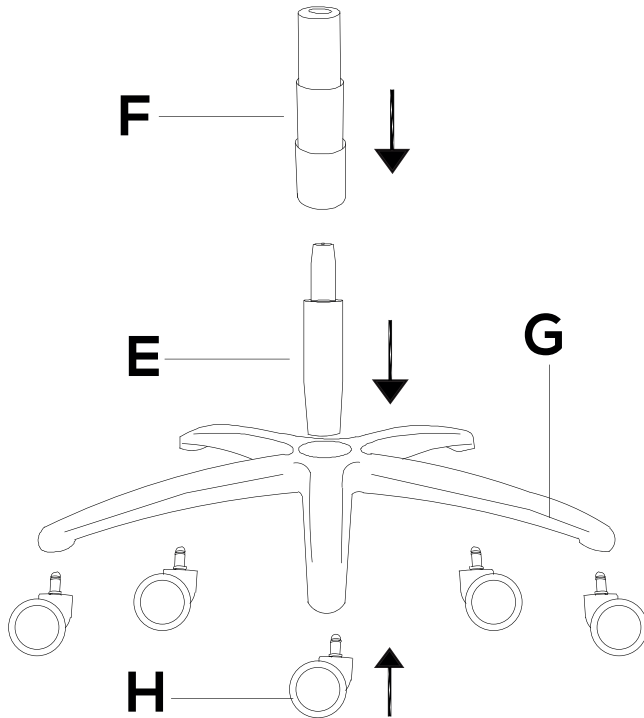

Step 1:

Insert the casters (H) into the star base (G). Some force may be required.

Place the gas lift (E) into the center of the base and press down until secure. Slide the cover (F) over the gas lift.

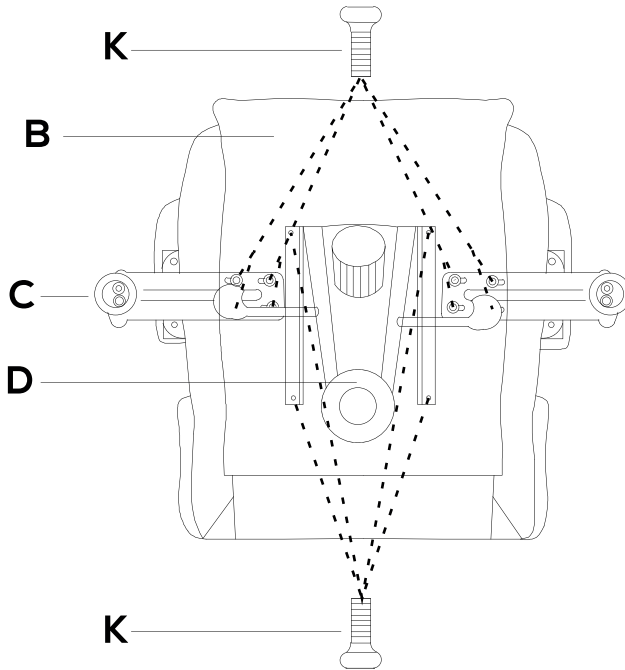

Step 2:

Turn the seat (B) upside down and install the adjustment mechanism (D).

Note: Check the arrow/label for the correct orientation.

Secure it with screws (K) using an X-pattern. Next, attach the armrests (C) (check the L/R markings) using screws (K).

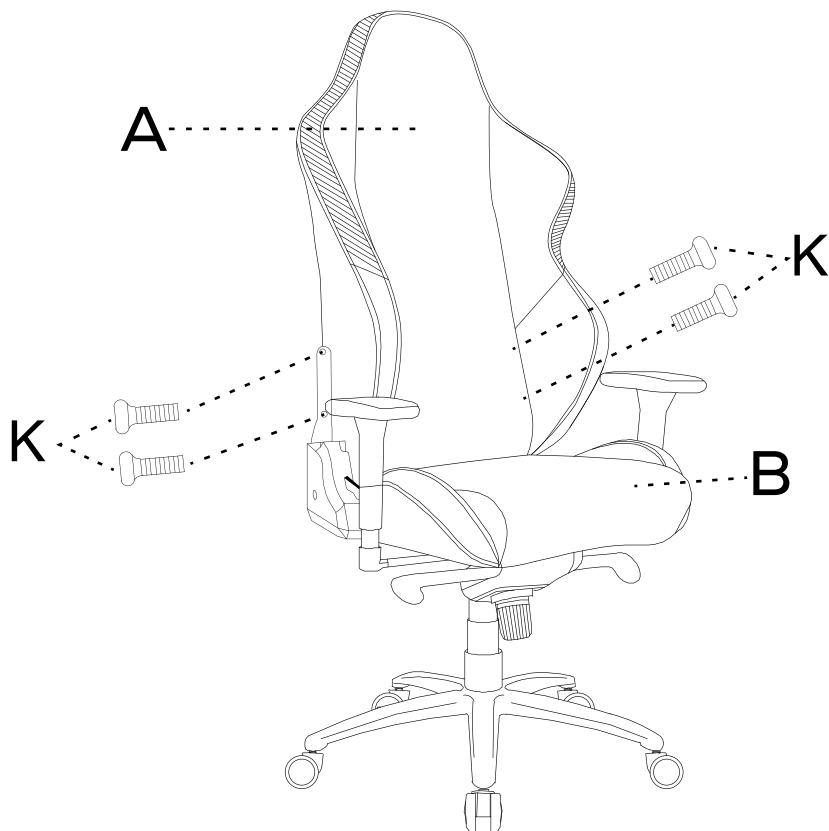

Step 3:

Place the backrest (A) between the seat connectors and secure it with screws (K). Tighten all 4 screws evenly to ensure the backrest stays straight.

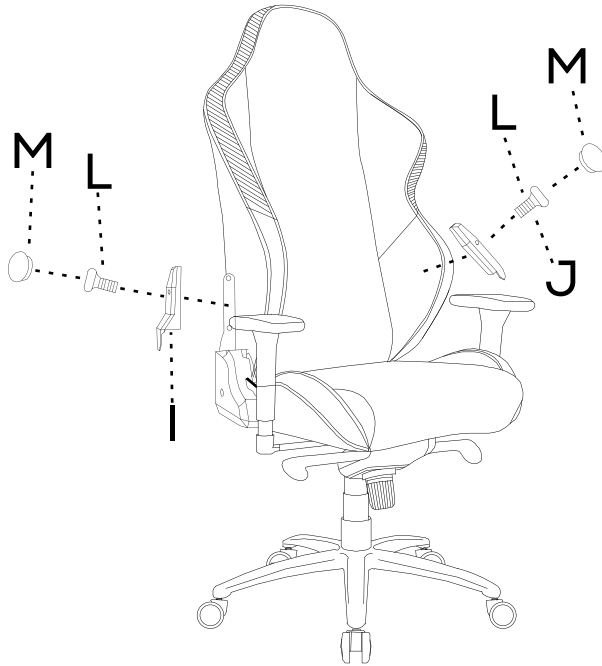

Step 4:

Attach the side covers (I & J) using screws (L) and hide the holes with the caps (M). Optionally, attach the headrest and lumbar cushions for even better support.



If preferred, the headrest and lumbar support cushions may be utilized to enhance ergonomic comfort. However, even without these accessories, the chair maintains adequate structural and postural support.

CHAIR FUNCTIONS

Frog Mechanism:

The Frog mechanism consists of 2 levers and 1 sensitivity control for the rocking mode. The right lever adjusts the height of the chair's gas lift, while the left lever activates or deactivates the rocking mode. The central adjustment control regulates the sensitivity of the rocking mode, allowing you to customize the chair's tilt experience according to the user's preference.

Backrest Lever:

On the right side of the chair, you will find a lever that allows you to adjust the backrest angle according to your preference, providing greater comfort during use.

CHAIR SPECS

Backrest: Reclining

Wheels: PU, 60 mm

Foam: Molded

Armrests: 3D

Base: Metal, 350 mm

Upholstery: Suede + PU

Mechanism: Frog

Recline angle: 90–180°

Lockable recline: Yes

Height adjustment: 6 cm

Frame material: Metal

Gas lift class: Class 4

Backrest density: 45

Seat density: 45

**THANK YOU FOR CHOOSING PICHAU GROUP
AS PART OF YOUR JOURNEY.**

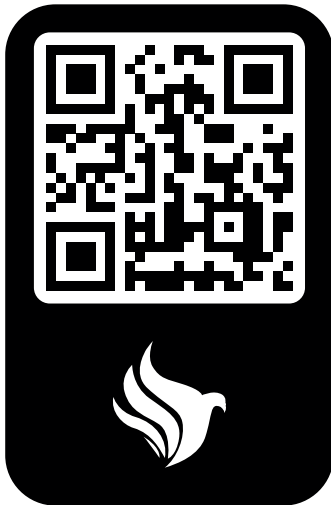

**EXPLORE OUR WEBSITES AND FIND THE
IDEAL PRODUCT TO ELEVATE YOUR EXPERIENCE.**

